

# Traveling Wave Tubes (TWT): Theory of Operation

## Communications & Power Industries

A TWT performs as a wideband microwave amplifier. This wideband amplification feature is obtained by the use of an interaction circuit which is essentially a transmission line and does not usually contain any resonant

All TWTs incorporate the basic components shown in Figure 1. These components include an electron gun (composed of a cathode, a control or modulating grid, and an accelerator), which produces an electron beam; an RF circuit (delay line), which propagates a microwave signal in a manner that permits interaction between the beam and the signal; an attenuator, which isolates the input and output sections to prevent oscillations; and a collector, which removes the unused beam energy.

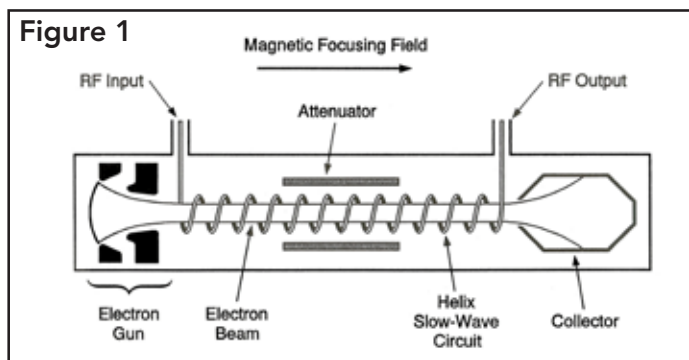

In addition, a magnetic field along the axis of the device (not shown) is used to focus the electron stream. Although TWT's may differ widely in size and construction, depending on the application, the basic theory of operation is the same for all types.

The principle of operation of a TWT is strikingly simple. As illustrated here, an electron beam is emitted from the cathode and accelerated toward the collector at the opposite end of the device. The electrons of the beam are surrounded by an RF wave with a strong field component in the direction of the beam travel. If the velocities of the beam and the wave are nearly the same, interaction takes place.

The delay line slows the RF wave down to the velocity of practical beams. This line is constructed so that the field components are primarily longitudinal in the vicinity of the beam. If a helix is used as the delay line, the RF wave actually travels along the path of the helix, but the beam sees only the much longer and slower wave components in the longitudinal direction; that is in traveling around one turn of the helix, the wave proceeds forward only by one pitch. The resultant velocity is a fraction of the original wave velocity.

### Characteristics of Ring Loop TWTs

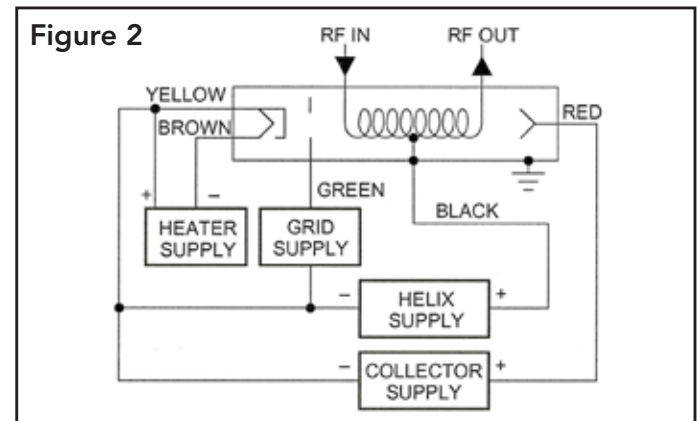

The Ring Loop TWTs are best known for an ability to amplify microwave signals simultaneously over a radar band of frequencies. A Ring Loop TWT is illustrated schematically in Figure 2, which also shows the power supplies to operate the TWT. This TWT consists of an electron gun (composed of a heater, cathode, and control anode), a helix (slow-wave structure), an attenuator, a collector, and an input and an output coupling element

Four sources of power are normally required to operate a Ring Loop TWT: heater power, regulated beam power, gain or modulation control power, and collector power. The electron beam in some TWTs is focused by electrostatic or electromagnetic methods, and in these situations, a power source is required to operate the beam focusing device.

In normal operation, an RF signal introduced at the cathode end of the helix travels along the circumference of the helix at approximately the velocity of light, although the velocity in the direction of the beam is reduced by the pitch-to-circumference ratio of the helix. When the voltage on the helix is properly adjusted, the velocity of the beam electrons is made slightly greater than the velocity of the RF signal. Electrons emitted from the cathode transfer energy to the RF signal on the helix as the signal velocity modulates the beam on the way to the collector. This is known as forward-wave amplification in contrast to TWT's that operate as backward-wave amplifiers. In backward-wave amplification, the RF signal is introduced at the collector end of the helix and travels down the helix in the direction opposite to that of the beam.

Electrons intercepted by the collector of the TWT are returned to the cathode through an external collector supply. Resultant helix DC interception is returned to the cathode through an external overload relay and a regulated beam supply. The overload relay removes beam power when the helix current becomes excessive, which protects the TWT from self-destruction. Modulation in the Ring Loop TWT is accomplished by applying the carrier signal to the RF input element and applying the intelligence to the control anode. By this, the TWT is made to either amplify or phase or pulse modulate the RF carrier signal, depending on the applied signal and the TWT parameters. For pulse operation, or modulation, a TWT operates at the same helix voltage as the TWT would operate under cw conditions. For a given TWT type, therefore, the peak power output can be made larger than the cw power output only by an increase in the beam current. Different methods of modulating the beam current are available.

Ring Loop backward wave amplifiers have very narrow active bandwidths for which gain is possible but the active bandwidth is voltage tunable. Therefore such TWTs were used originally as tunable filters with gain. These had applications in electronic countermeasure systems.

## Effects of Input Conditions on TWTs

Input conditions that affect TWT operation include beam current, drive power, helix voltage, drive frequency, and heater voltage. For a given beam current, the power output of a TWT amplifier is a function of the RF drive power as shown in Figure 3.

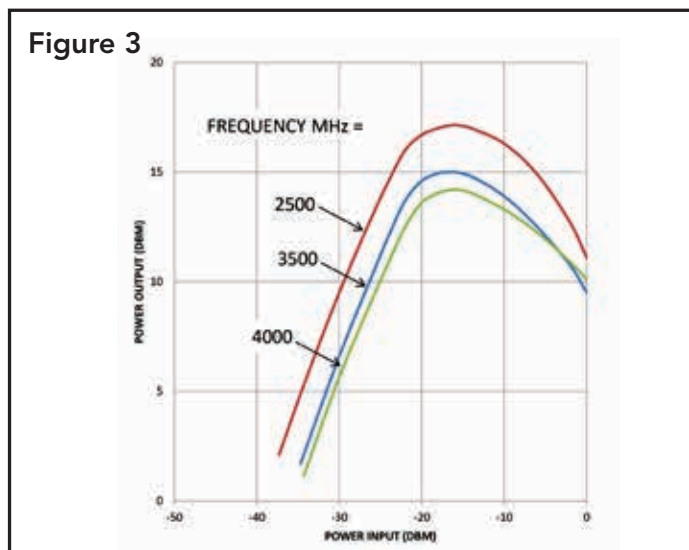

The gain is essentially constant at a given frequency for low RF drive levels, but decreases at higher levels. When the RF electric field becomes too strong, as a result of either amplification or input signal, the amount of energy which the beam can deliver to the wave reaches a maximum limit. This condition, known as the saturation point of the TWT, represents the maximum power which can be delivered for a given condition of beam current. If the input power is increased beyond the value which

# Traveling Wave Tube Theory of Operation pg. 3

causes saturation, an actual decrease in power output results. (An increase in the beam current, of course, produces a corresponding increase in saturation power and gain.)

Because the gain of a TWT amplifier depends on beam current, the maximum gain that can be obtained from a given TWT is limited by the stability limit, that is, the beam current value at which the TWT begins to oscillate; the safe emission limit of the cathode; and the maximum current which can be focused through the helix without causing excessive current to be intercepted by the helix or other TWT elements and thereby producing overheating. For high power operation, the TWT must employ elements which can dissipate the heat created by the RF wave and intercepted beam current. In high power TWT amplifiers, therefore, a maximum value is often specified for helix and collector power dissipation.

## Effects of Output Conditions on TWTs

The accuracy of the impedance match between the input and output couples and the helix of a TWT determines not only the RF power applied to and extracted from the helix, but also the power reflected from the input coupler back to the driving source, the power reflected to the helix by the output coupler, and the flatness of the gain of the TWT across a band of frequencies.

Normally, TWT coupler are capable of providing impedance matches with voltage-standing-wave ratios (VSWR) of less than 1.5 for a cold match and less than 2 for a hot match. A cold match is with no beam present in the helix, and a hot match is with a beam in the helix. Figure 4, is a chart of the hot and cold input and output VSWRs for a typical TWT application.

Cold-match VSWR's of less than 1.5 over very wide frequency bands are achieved in most TWT's by the use of precision wound couplers and properly matched connecting section of coaxial lines or waveguides between the couplers and external RF connections.

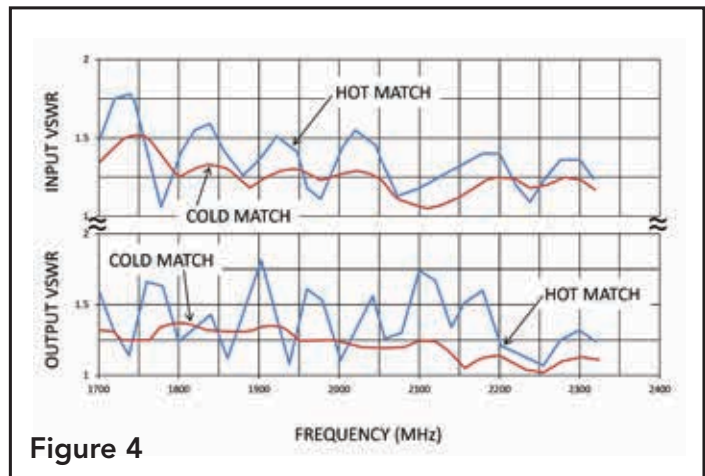

## TWT Cooling

Sufficient cooling must be available at the collector, electron gun, and body of a TWT to remove heat dissipated by these elements and thereby maintain the temperature at a safe operating level. Normally, a TWT is designed for either water or forced air or convection cooling. Most solenoids are designed for either water or forced-air cooling; however, some contain Teflon® or silicon insulation and are, therefore, cooled sufficiently by convection means.

In using water coolant, a closed circulating system is desirable to hold the content of oxygen and carbon dioxide to a low level. A flow interlock should be used in the closed system to remove all voltages from the TWT if the water coolant flow falls below a nominal pressure level.

Many low and medium power TWT's use cooling fins or radiators attached to the collector casing to absorb heat dissipated by the collector. Air is then forced across the surfaces of these cooling elements.

With a history of producing high quality products, we can help you with TWTs and other radar products.

**Contact us at [ElectronDevices@cpii.com](mailto:ElectronDevices@cpii.com) or call us at +1 (978) 922-6000.**